



Anti-Theft System

Operation & Installation Guide

WARNINGS & SAFETY INSTRUCTIONS

 **Do not operate WiTi unless you have read and understood this manual. Ensure WiTi is installed as per the instructions, failure to do so will void warranty.**

Ensure the cable used to install **WiTi** Anti-Theft is of adequate thickness to provide the necessary current for the circuit.

WiTi Anti-Theft must be installed away from environmental conditions that may cause damage to the units circuitry including water, salt spray and humidity.

WiTi Anti-Theft is connected to the internal house battery of the caravan or trailer, insufficient charge of the house battery will affect the performance of the Anti-Theft functions. The condition of the battery in the caravan or trailer must be maintained and checked.

NOTE : When servicing the electric brakes or magnets it is recommended **WiTi** is disconnected to prevent accidental short circuits.



Warning : The remote controls supplied with WiTi Anti-Theft contain button / coin batteries. These batteries are hazardous and can cause severe or fatal injuries in 2 hours or less if swallowed or placed inside any part of the body. These batteries must be kept away from children (whether the battery is new or used). Medical advice must be sought immediately if it is suspected the battery has been swallowed or placed inside any part of the body.

WiTi ANTI-THEFT SYSTEM

WiTi detects movement via a highly sensitive gyroscope and accelerometer. In the event an attempt is made to gain access to or tow the caravan or trailer the Anti-Theft system will be activated. All the lights flash, the alarm sounds and the brakes are applied making it practically impossible to tow the caravan or trailer. This continues as long as movement is detected. Once movement ceases **WiTi** Anti-Theft will reset after 30 seconds. The brakes are applied initially for 5 seconds and then released if there is no movement to prevent the battery from discharging unnecessarily.

To activate **WiTi** Anti-Theft, press and hold the button on the remote control for ½ a second, the side and front markers and indicators will flash once followed by a 3 second safety pause and then a double flash to indicate the system is armed. The Alarm Status LED will illuminate. To deactivate, press and hold the button on the remote control for ½ a second and the lights will flash once and the Alarm Status LED will switch off.

WiTi incorporates an advanced safety system to ensure the system cannot be accidentally activated whilst the caravan or trailer is being towed. After activating the system, if movement is detected during the 3 second safety pause the system will not arm. The lights will not flash twice and the Alarm Status LED will not illuminate. The system must be deactivated again by pressing the remote control button for ½ a second before another activation sequence is attempted.

WiTi GPS TRACKING

WiTi features an optional GPS Tracker. If supplied, connect the GPS Tracker to the corresponding plugs on the wiring loom. Refer to the **WiTi** GPS section for activation and operating instructions.

Specifications

	Trailer Unit
Nominal system voltage	12V
Operating voltage	9V-12V
Standby current	<10mA
Operating temperature	-20C – 60C
Max. trailer axles	3 Axles
Braking circuit max draw	25A
Maximum rated current	30A
Weight	300g

Contents

1. Trailer Unit
2. Alarm Horn
3. 2 Remote Controls



INSTALLATION INSTRUCTIONS

- The unit must be installed vertically and facing either the front or rear of the caravan or trailer with the wiring harness protruding from the bottom of the unit. **WiTi** uses gravity to initialise the gyroscope and detects acceleration in the direction of travel. If not installed correctly functionality will be compromised. The unit must be installed inside the caravan or trailer and it is recommended the unit is installed towards the front of the caravan or trailer. This will make the unit more sensitive to attempts to hitch up or knocks onto the tow hitch. The unit can be screwed onto a panel through the mounting lugs and using appropriate sized screws.
- **The horn must be installed at least 1 metre away from the Trailer Unit and on a different mounting surface to prevent interference from vibration. If the horn is installed too close to the Trailer Unit, the vibration will be detected as movement and the alarm will continue sounding.** The horn is weather proof so it can be installed externally.
- The Alarm Status LED outputs must be connected to the supplied 3V LED as per the wiring instructions. The LED will light when the alarm is armed and switch off when the alarm is disarmed. The LED will flash if a short circuit or overload is detected. Install the LED in an area which is visible to the user.
- The caravan or trailer battery must be connected to an acceptable charging circuit - either solar panels, anderson plug or DCDC charger.

CIRCUIT PROTECTION AND FAULT CONDITIONS















In the event a short circuit or an overload is detected, **WiTi** Anti-Theft will disable all functions and the Alarm Status LED will flash. The Alarm Status LED will continue to flash until the short circuit is repaired and the unit restarted by pressing the button on the remote control.

NOTE : When servicing the electric brakes or magnets it is recommended **WiTi** is disconnected to prevent accidental short circuits.

WIRING INSTRUCTIONS

The trailer unit is fitted with a 24 pin plug and separate harnesses for the GPS Integration option. **WiTi** is installed in parallel with the existing wiring harness on the caravan.

Generally the wiring harness for the caravan or trailer will run down the A-frame and chassis and exit near the axle where it will split to the brakes and lighting circuits. This is a good location to connect into the harness. **WiTi** works in conjunction with other circuits for lighting and braking and is installed in parallel with other circuits. Locate the wiring harness on the caravan and connect into the corresponding wiring as per the guide below. **WiTi** wiring is colour coded as per Australian standards.

Colour	Label	Function
	L-Ind-Lt	Left Indicator
	R-Ind-Lt	Right Indicator
	Brake-Lt	Brake Light
	Head-Lt	Park Lights and Markers
	Rev-Lt	Reverse Lights
	SrBrake	Electric Brake Output
	Earth RTN	Earth Return
	IGN-Out	Ignition feed - Not used on WiTi Anti-Theft System
	Horn +	Alarm Horn Pos output. Connect to horn
	Horn -	Alarm Horn Negative. Connect to horn
	LED +	Alarm Status LED 3.3V+. Connect to positive on LED
	LED -	Alarm Status LED 3.3V-. Connect to negative on LED
	BAT +	12V+ connect to positive terminal on house battery and protect with a 30A fuse.
	BAT -	NEG connect to negative terminal on house battery.

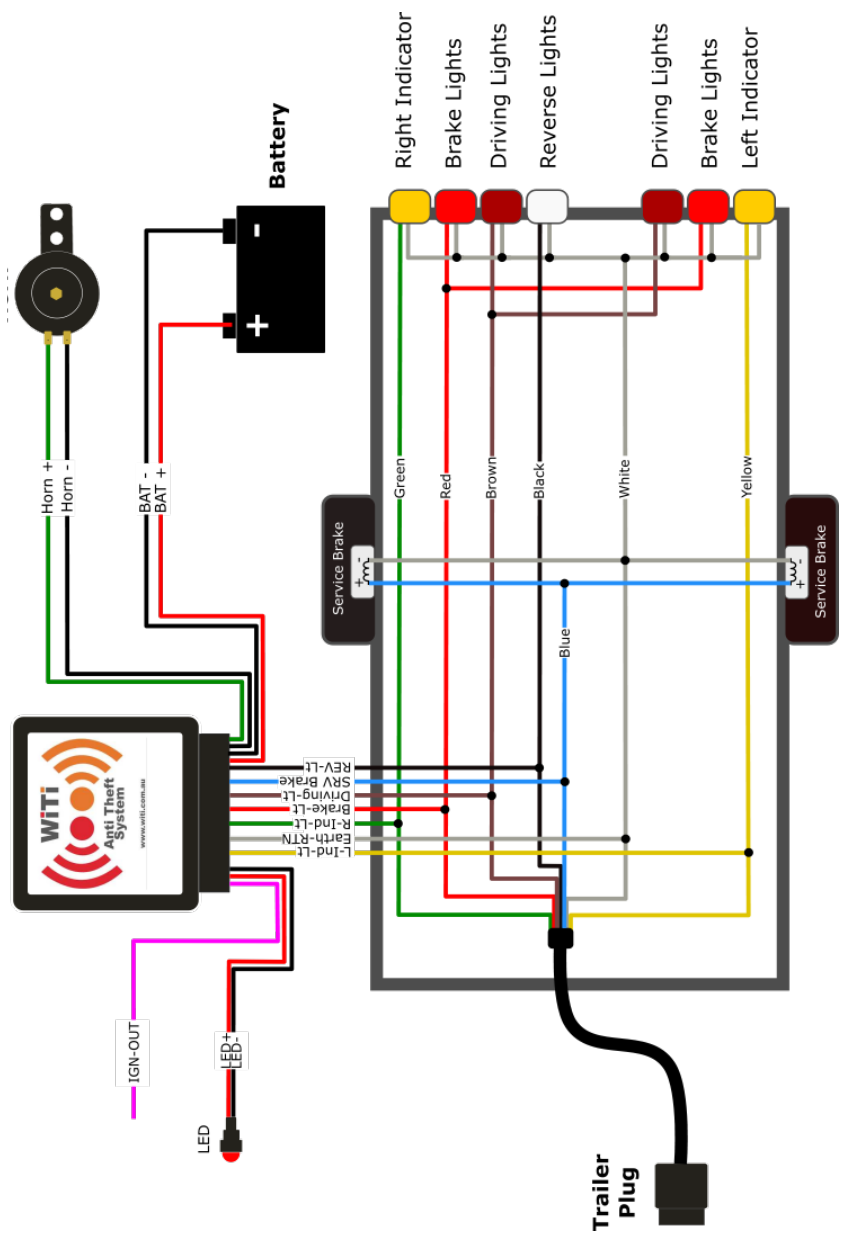

CHANGING REMOTE CONTROL BATTERIES



Warning : The remote controls supplied with WiTi Anti-Theft contain button / coin batteries. These batteries are hazardous and can cause severe or fatal injuries in 2 hours or less if swallowed or placed inside any part of the body. These batteries must be kept away from children (whether the battery is new or used). Medical advice must be sought immediately if it is suspected the battery has been swallowed or placed inside any part of the body.

1. Remove the cover off the top of the remote control by gently prying it open with a small screwdriver. Place the screwdriver between the top cover and the bottom cover and gently pry it open. There are four clips, two either side that need to be opened.
2. Remove the old batteries and replace them with two new batteries taking care to observe the markings and ensure + is facing upwards as in the picture.
3. Replace the cover taking care to make sure it is firmly replaced and all four locking tabs are engaged.



LIMITED WARRANTY

If Leisure Technologies determines that you are covered by a warranty as set in the Australian consumer law the company shall at its expense: (a) repair the product or replace the product with a new unit (which may have used refurbished parts of similar quality); (b) ship the repaired or replaced unit back to you; (c) warrant the repaired or replaced product for a reasonable period; and/or (d) refund money paid for the product. The Company has the discretion as to which remedy applies.

Warranty period

The warranty period starts on the date of purchase and ends 24 months later. For the purpose of this limited warranty, the date of purchase is the date indicated on the original bill of sale or received invoice for the product from the vendor from which you acquired this product.

How to get warranty service

During the warranty period, if you wish to return a defective product you may contact us via www.witi.com.au. You may then return the defective product to the address given accompanied by an acceptable proof of purchase (a bill of sale or received invoice).

What is not covered

The limited warranty does not cover a product:

- for which you are not the original purchaser;
- that is damaged by using in a way that was unreasonable or unintended;
- that is returned after the applicable warranty period set out above has expired;
- that has been installed other than per the product installation guidelines;
- that has been maintained, altered or modified, opened or repaired, other than by the company or by a company authorised service centre;
- that has been physically damaged, other than by the company or a company authorised service centre.

To the extent permitted by law, Leisure Technologies, its directors, officers, employees, suppliers and agents, shall not be liable for injury to persons or property, or for any indirect, special, incidental or consequential, punitive or exemplary damages and liability and shall be limited to the amount you paid for the product.

Disclaimer

- WiTi products are designed for installation by reasonably competent consumers. Consumers are taken to have sufficient knowledge of the intended caravan or trailer unit and its appropriateness for the installation of any WiTi products.
- Installation of WiTi products may require consumers to have knowledge and experience using powered tools and electrical wiring. Consumers without such knowledge are to refrain from attempting any installation of WiTi products and to consult their nearest WiTi specialist or qualified Auto Electrician.
- Prior to the installation of any WiTi product consumers are taken to have comprehensively read and understood the appropriate WiTi operation and installation guide included with the product.
- It is the consumer's sole responsibility to have WiTi products properly installed on their vehicle and/or trailer units along with any modifications necessary for the proper installation of WiTi products.
- Consumers are solely and completely responsible for evaluating their trailer units to ensure that the trailer units, and each part thereof, is appropriate, adapted, and applicable for installation and use of WiTi products.
- Any and all WiTi unit damages caused by a consumer's failure to modify the caravan or trailer properly for installation and use of one or more WiTi products not covered by this disclaimer is the sole responsibility of the consumer.
- Leisure Technologies Pty Ltd and their distributors and resellers also expressly disclaims all liability for direct, indirect, special, incidental, or consequential damages, including but not limited to, damage or loss of property or equipment, injury to person whether physical or not, loss of profits or revenue, cost of purchase or replacement of goods, or claims of customers of the purchaser that result from the incorrect installation of any WiTi Anti-Theft unit or subunit.

Other important notices

To the extent permitted by law, this limited warranty constitutes the entire agreement on the subject matter and supersedes any prior agreement or understanding, written or oral. Where used herein, the company shall mean Leisure Technologies Pty Ltd and its subsidiaries and associates.

Our goods come with guarantees that cannot be excluded under the Australian consumer law. You are entitled to a replacement or refund for a major failure and for compensation for any other reasonably foreseeable loss or damage. You are also entitled to have the goods repaired or replaced if the goods fail to be of acceptable quality and the failure does not amount to a major failure. The benefits under your warranty are in addition to other rights and remedies under the law in relation to the product.

Leisure Technologies Pty Ltd