

↗ DOMETIC REFRIGERATION 10-SERIES



RMD 10.5XS

EN

Absorption refrigerator
Operating manual

© 2020 Dometic Group. The visual appearance of the contents of this manual is protected by copyright and design law. The underlying technical design and the products contained herein may be protected by design, patent or be patent pending. The trademarks mentioned in this manual belong to Dometic Sweden AB. All rights are reserved.

Please carefully read and follow all instructions, guidelines and warnings included in this product manual in order to ensure that you install, use and maintain the product properly at all times.

By using the product, you hereby confirm that you have read this disclaimer, all instructions, guidelines and warnings carefully and that you understand and agree to abide by the terms and conditions as set forth herein.

You agree to use this product only for the intended purpose and application and in accordance with the instructions, guidelines and warnings as set forth in this product manual as well as in accordance with all applicable laws and regulations.

A failure to read and follow the instructions and warnings set forth herein may result in an injury to yourself and others, damage to your product or damage to other property in the vicinity.

Dometic accepts no liability for any loss, damage or injury incurred, directly or indirectly, from the installation, use or maintenance of the product not in compliance with the instructions and warnings in the product manual.

This product manual, including the instructions, guidelines and warnings, and related documentation may be subject to changes and updates. For up-to-date product information, please visit: documents.dometic.com, dometic.com.

Table of contents

1	Explanation of symbols	4
2	Safety instructions	4
3	Scope of delivery	9
4	Intended use	9
5	Technical description	10
6	Using the refrigerator	13
7	Troubleshooting	27
8	Cleaning and maintenance	31
9	Warranty	33
10	Disposal	34
11	Technical data	35

1 Explanation of symbols

**WARNING!**

Safety instruction: Indicates a hazardous situation that, if not avoided, could result in death or serious injury.

**CAUTION!**

Safety instruction: Indicates a hazardous situation that, if not avoided, could result in minor or moderate injury.

**NOTICE!**

Indicates a situation that, if not avoided, can result in property damage.

**NOTE**

Supplementary information for operating the product.

2 Safety instructions

The manufacturer accepts no liability for damage in the following cases:

- Damage to the product resulting from mechanical influences and incorrect connection voltage
- Alterations to the product without express permission from the manufacturer
- Use for purposes other than those described in the operating manual

2.1 General safety



WARNING! Failure to obey these warnings could result in death or serious injury.

Electrocution hazard

- Installation and removal of the device may only be carried out by qualified personnel.
- Do not operate the device if it is visibly damaged.
- If the power cable for this refrigerator is damaged, it must be replaced by the manufacturer, customer service or a similarly qualified person in order to prevent safety hazards.
- This device may only be repaired by qualified personnel. Improper repairs can result in considerable danger or damage to the device.

Fire hazard

- The refrigerant in the refrigerant circuit is highly flammable. In the event of any damage to the refrigerant circuit (smell of ammonia):
 - Switch off the device.
 - Avoid naked flames and sparks.
 - Air the room well.

Explosion hazard

- DO NOT SPRAY AEROSOLS IN THE VICINITY OF THIS DEVICE WHILE IT IS IN OPERATION.
- Do not store any explosive substances, such as spray cans with propellants, in the device.

Health hazard

- This device is not intended for use by persons (including children) with reduced physical, sensory or mental capabilities, or lack of experience and knowledge, unless they have been given supervision or instruction concerning use of the device by a person responsible for their safety.
- Cleaning and user maintenance may not be carried out by unsupervised children.
- Children must be supervised to ensure that they do not play with the device.

General hazard

- DO NOT USE OR STORE FLAMMABLE MATERIALS IN OR NEAR THIS DEVICE.
- DO NOT PLACE ARTICLES ON OR AGAINST THIS DEVICE.
- DO NOT MODIFY THIS DEVICE.

**NOTICE! Damage hazard**

- Keep the condensation opening clean at all times.
- The device lighting may only be replaced by a qualified service agent.
- Do not use a high-pressure cleaner near the ventilation grill when cleaning the vehicle.
- Never pull the plug out of the socket by the connection cable.
- The device may not be exposed to rain.

2.2 Safe operation



CAUTION! Failure to obey these cautions could result in minor or moderate injury.

Risk of injury

- Close and lock the device door before beginning a journey.
- The cooling aggregate at the back of the device becomes very hot during operation. Protect yourself from coming into contact with hot parts when removing ventilation grills.



NOTICE! Damage hazard

- Do not use electrical devices inside the device unless they are recommended by the manufacturer for that purpose.
- Ensure that the ventilation openings are not covered.

2.3 Safety when operating with DC power



NOTICE! Damage hazard

Only select operation with DC power supply (battery mode) if the vehicle engine is running and providing sufficient voltage to the light system, or if you are using a battery monitor.

2.4 Safety when operating with AC power



NOTICE! Damage hazard

- Check that the voltage specification on the type plate is the same as that of the power supply.
- Only use the cable supplied to connect the refrigerator to the AC mains.

2.5 Safety precautions when handling liquid gas



WARNING!

- After use always disconnect the liquid gas cylinder.
- Store liquid gas cylinders away from heating or cooking devices and other light or heat sources in a well-ventilated area out of the reach of children.
- **Never** store liquid gas cylinders in unventilated areas or below ground level (funnel-shaped holes in the ground).

- **Never** store liquid gas cylinders in buildings such as garages.
- Any indoor storage must comply with AS/NZS 1596.
- Do not store liquid gas cylinders on their side.
- Keep liquid gas cylinders away from direct sunlight. The temperature should not exceed 50 °C.

2.6 Safety when operating with gas



WARNING! Failure to obey these warnings could result in death or serious injury.

Explosion hazard

- **Only** operate the device at the pressure shown on the type plate. Only use pressure controllers with a fixed setting which comply with the national regulations.
- Never operate the device with gas:
 - At petrol stations
 - In parking garages
 - On ferries
 - While driving
 - While transporting the caravan or mobile home with a transport vehicle or tow truck
- Never use a naked flame to check the device for leaks.
- In case of gas odor:
 - Close the gas supply cock and the valve on the cylinder.
 - Open all windows and leave the room.
 - Do not press an electric switch.
 - Put out any naked flames.
 - Have the gas system checked by a specialist.



NOTICE! Damage hazard

- Only use universal LPG gas.



NOTE

- Ignition problems may occur at altitudes above 1000 m. Switch to a different energy source.

2.7 Safety when operating



CAUTION! Failure to obey these cautions could result in minor or moderate injury.

Health hazard

- Make sure that you only put items in the device which may be chilled at the selected temperature.
- Opening the door for long periods can cause significant increase of the temperature in the compartments of the device.
- Food may only be stored in its original packaging or in suitable containers.
- Store raw meat and fish in suitable containers in the device, so that it is not in contact with and cannot drip onto other food.
- If the device is left empty for long periods:
 - Switch off the device.
 - Defrost the device.
 - Clean and dry the device.
 - Leave the door open to prevent mould developing within the device.

Risk of injury

- The device door or the freezer door can completely detach from the device if used incorrectly. Push the doors closed until you hear a clear click at the top and bottom.
- Do not lean on the open device door.



NOTICE! Damage hazard

- If the door is not locked correctly on the opposite side, push on that side at the top and the bottom until it locks in place.
- Only store heavy objects such as bottles or cans in the device door, in the vegetable compartment or on the bottom shelf.



NOTE

- Ask your vehicle manufacturer if the battery management of your vehicle shuts down the devices to protect the battery.
- Put the device door and the freezer door into the winter position if you are not going to use the device for a longer period of time. This prevents mold from forming.
- For ambient temperatures of +15 °C to +25 °C, select the MID temperature setting.

3 Scope of delivery

- Refrigerator
- Quick-Start Guide
- Operating manual

4 Intended use

The device is suitable for:

- Installation in caravans and motor homes
- Providing refrigeration, freezer and storage space for food



CAUTION! – Health hazard!

Please check if the cooling capacity of the refrigerator is suitable for storing the food you wish to cool.

The device is **not** suitable for:

- Storing medications
- Storing corrosive substances or substances that contain solvents
- Freezing previously unfrozen food

This product is only suitable for the intended purpose and application in accordance with this instruction. Any other use, deviating from the intended use, is not allowed! Dometic accepts no liability for any loss, damage or injury incurred, directly or indirectly due to other as the intended use.

5 Technical description

The refrigerator is an absorption refrigerator and is designed for operation

- on a 12 V DC power supply
- on an AC power supply
- with liquefied universal LPG gas

The refrigerator has an automatic operating mode that selects the most economical connected type of energy. The refrigerator unit operates silently.

The refrigerator will attempt ignition three times for 30 seconds with two minutes between each attempt. If after this the flame does not ignite see chapter “Troubleshooting” on page 27).

The refrigerator is equipped with an automatic safety device which automatically terminates the gas supply to the burner approximately 30 seconds after the flame goes out and remains out.



NOTE

To correctly operate on 12 V DC the towing vehicle must provide sufficient voltage to the refrigerator. On some vehicles, the battery management system may automatically switch off the 12 V DC supply to protect the battery. Ask your vehicle manufacturer for more information.

5.1 Components

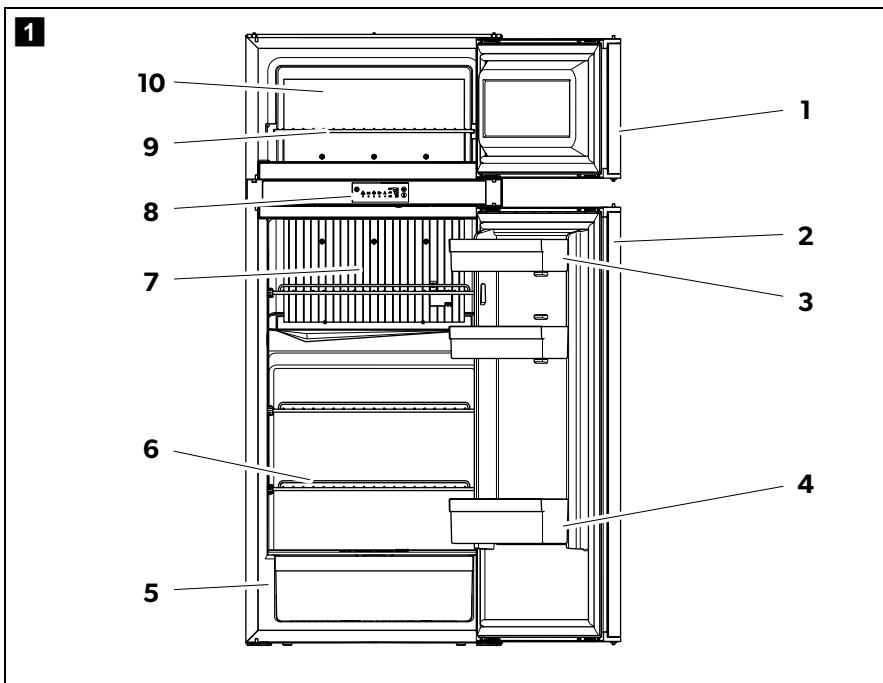

No. in fig. 1 Description

1	Freezer compartment door
2	Refrigerator door
3	Top door bin
4	Bottom door bin with bottle holder
5	Fruit and vegetable section with VG Fresh base
6	Refrigerator shelf
7	Air duct
8	Control and display elements
9	Freezer shelf
10	Freezer compartment

5.2 Control and display elements

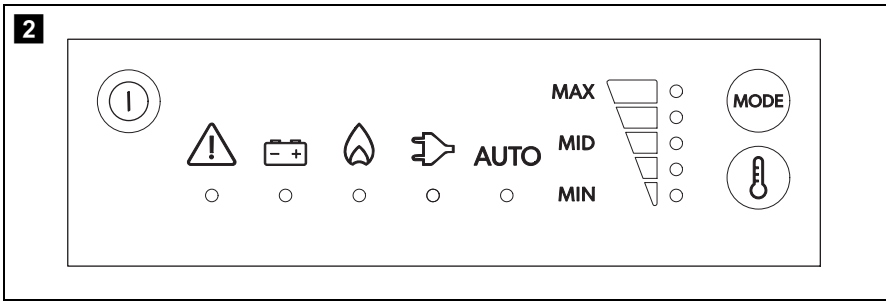

The LED display has the following operating and display elements (fig. 2):

Symbol	Description
	ON/OFF button
	Fault indication
	Operating with DC power
	Operating with gas
	Operating with AC power
AUTO	Automatic mode
	Temperature indication
	Energy selection button
	Temperature selection button

6 Using the refrigerator



NOTICE!

- Make sure that you only put items in the refrigerator which may be kept at the selected temperature.
- Make sure that items in the refrigerator do not block the openings of the cooling ventilation areas in the main compartment
- Foodstuff may only be stored in its original packaging or in suitable containers.



NOTE

- Before starting your new refrigerator for the first time, you should clean it inside and outside with a damp cloth for hygienic reasons.
- The cooling performance can be affected by:
 - the ambient temperature (e.g. when the vehicle is exposed to direct sunlight)
 - the amount of food to be stored
 - how often you open the door
- When using the refrigerator for the first time, there may be a mild odour which will disappear after a few hours. Air the living space well.
- Park the vehicle so that it is level, especially when starting up and filling the refrigerator before setting off on a journey.
- Approximately one hour after switching on, the freezer compartment of the refrigerator should be cold. The refrigerator reaches its operating temperature after a few hours.

NOTICE

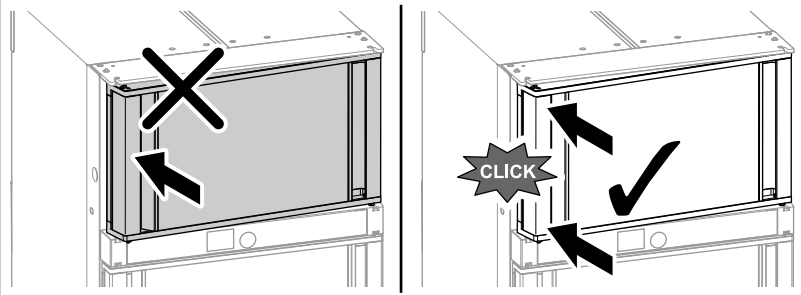
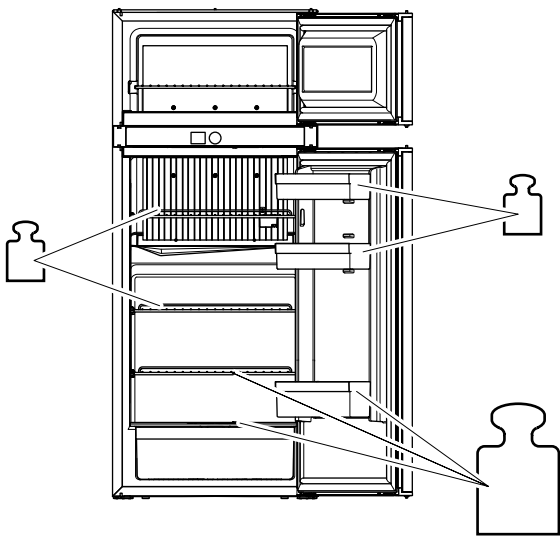
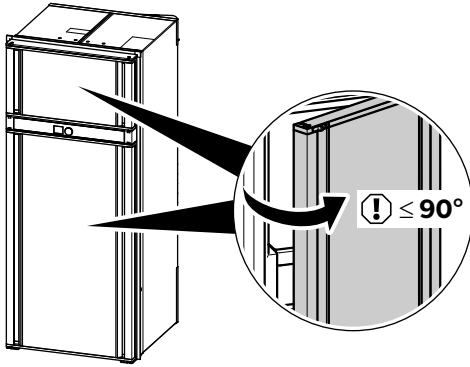

6.1 Tips for using the refrigerator optimally

When the temperature in the interior of the refrigerator exceeds +4 °C, the shelf life of goods that spoil quickly cannot be guaranteed. To attain an optimal cooling capacity in the interior of the refrigerator, observe the following information:

- Do not store goods in the refrigerator for the first 12 hours of operation.
- Protect the interior of the vehicle from warming up excessively (e.g. sunshades in the windows, air conditioner).
- Protect the refrigerator from direct sunlight (e.g. sunshades in the windows).
- Voltage fluctuations can have a negative effective on the cooling capacity. Check the temperature in the interior of the refrigerator regularly
 - when using DC power supply during the journey
 - when using AC power supply at the site of use

6.2 Energy saving tips

- Choose a well ventilated location which is protected from direct sunlight.
- Allow warm food to cool down first before keeping it cool in the refrigerator.
- Do not open the refrigerator more often than necessary.
- Do not leave the doors open for longer than necessary.
- Defrost your refrigerator as soon as a layer of ice forms.
- Avoid unnecessarily low temperature settings.
- Arrange the food in the refrigerator so that air can circulate inside.
- Leave a distance of at least 10 mm between the contents and ventilation openings on the vent cover.

6.3 Operation at high ambient temperatures

At high ambient temperatures in combination with high levels of humidity, condensation may form on the freezer compartment frame. The freezer compartment is equipped with a frame heater to reduce condensation on the frame of the freezer compartment.

The frame heater is switched on continuously in the following operating modes:

- AC operation
- DC operation (when the engine of the vehicle is running)

6.4 Switching on the refrigerator

- ▶ Press and hold the  button for 2 seconds.
- ✓ The refrigerator starts with the last selected settings.

6.5 Switching off the refrigerator

- ▶ Press and hold the  button for 4 seconds.
- ✓ A beep sounds and the refrigerator switches off.

6.6 Operating the refrigerator

Selecting the power source

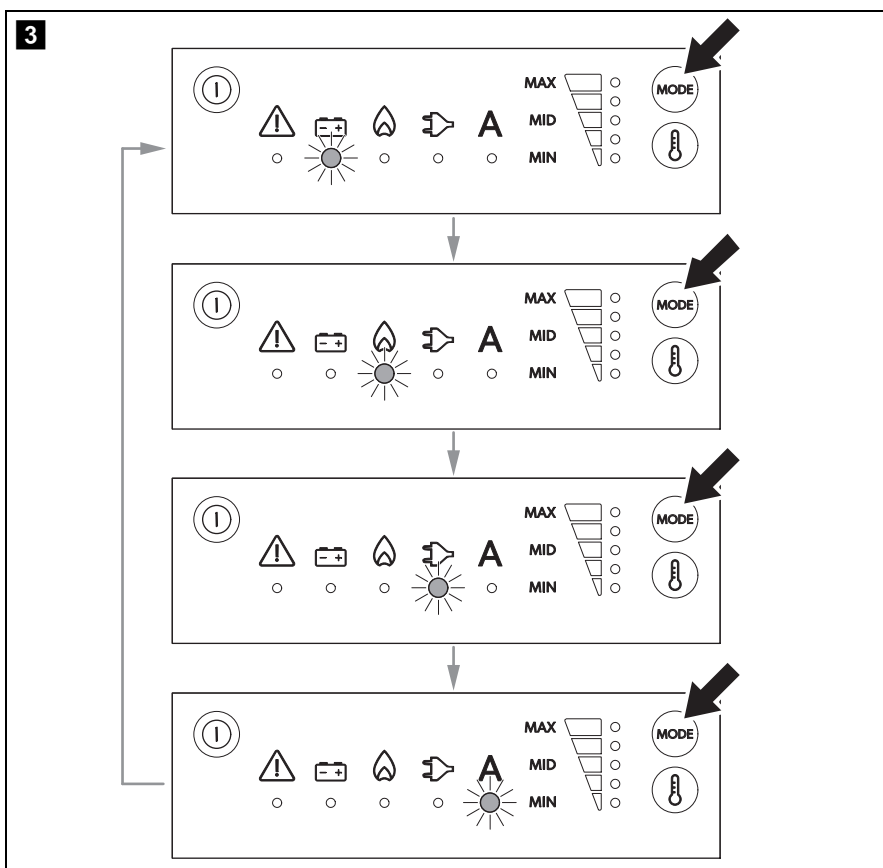

Selecting the cooling capacity



NOTE

For ambient temperatures of +15 °C to +25 °C, select the MID cooling capacity.

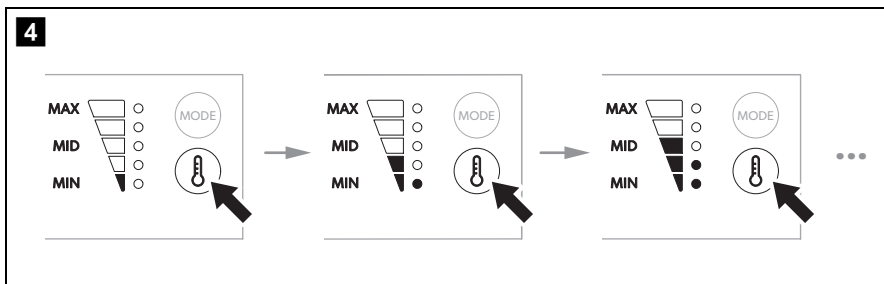

Fan operation

When switching on the device, the fan is switched on for a short time (function test). While the refrigerator is in operation the fan only switches on in the following situations:

- When the ambient temperature is above 32 °C
- When the set cooling temperature is not reached within 2 hours



NOTE

The fan function is always activated and can **not** be deactivated.

6.7 Tank stop mode



WARNING!

Turn off the refrigerator or select a different operating mode if refuelling takes longer than 15 minutes.

If the vehicle's ignition is switched off, the refrigerator will switch to tank stop mode for safety reasons. This blocks gas operation for 15 minutes. After that, the refrigerator automatically switches back to regular, automatic mode.

In tank stop mode the  LED flashes.

6.8 Stand-alone gas operation



WARNING!

In stand-alone gas mode, the refrigerator must be switched off manually during refuelling.





NOTE

- When there is no AC or DC connection, the batteries are drained even when the refrigerator is off.
- Remove the batteries when the refrigerator is not in use to prevent leakage.

For stand-alone gas mode, the battery packs must be loaded with batteries (see chapter “Optional battery backup/Stand-alone gas operation” on page 26). A connection to an AC or DC power supply is then no longer necessary.

When using 12 batteries (type AA), the refrigerator can be operated in stand-alone gas mode for 2 to 3 days.

Please note the following special features for stand-alone gas mode:

- The refrigerator interior lighting remains switched off.
- Stand-alone gas mode is indicated by the flashing of the  LED every 15 seconds .
- The batteries of the battery packs must be replaced when the error  /  is displayed.

6.9 Using the refrigerator doors

Disabling the door lock

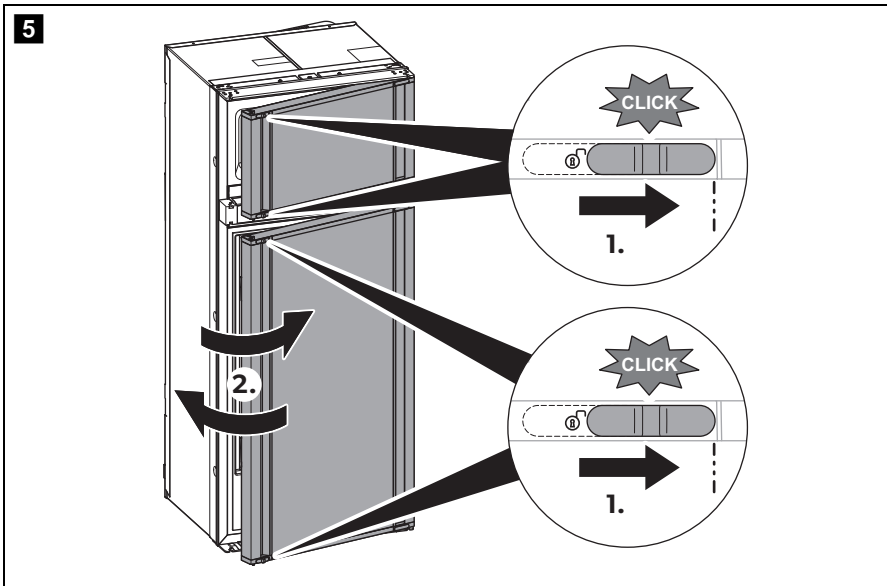

- ▶ Disable the door lock as shown (fig. **5**).
- ✓ The refrigerator door is easy to open and close but will not be secured when closed.

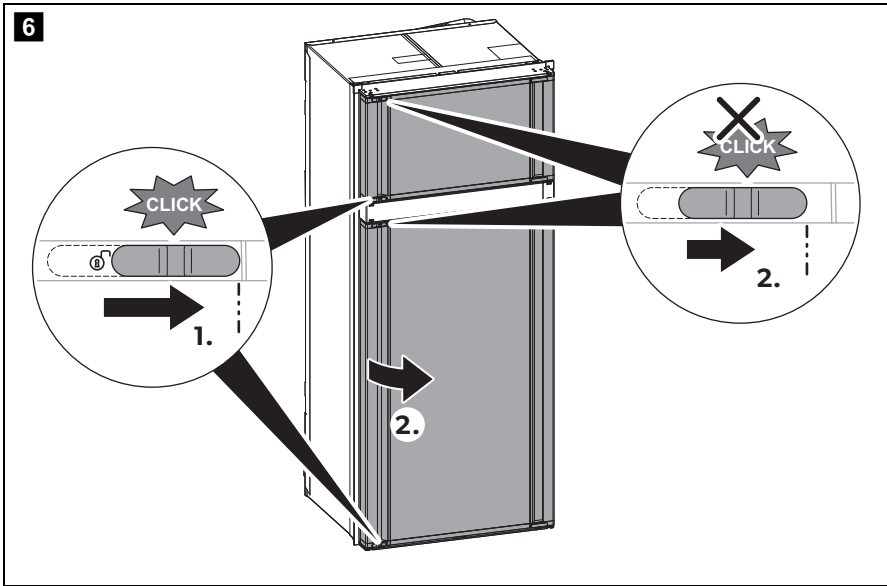
Securing the refrigerator door at the top automatically

► Release and open the refrigerator door as shown (fig. 6).

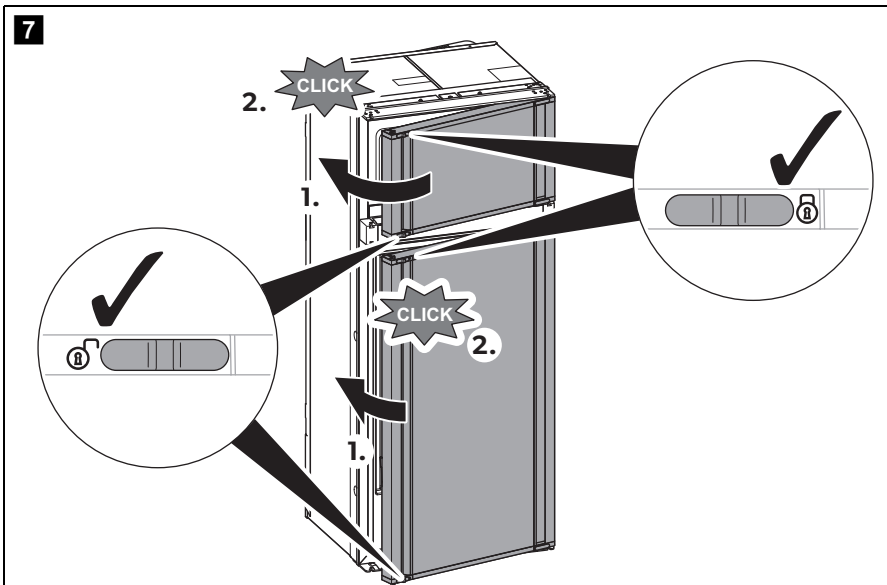

✓ The refrigerator door is automatically secured at the top after closing (fig. 7).

Securing the refrigerator door before starting to drive

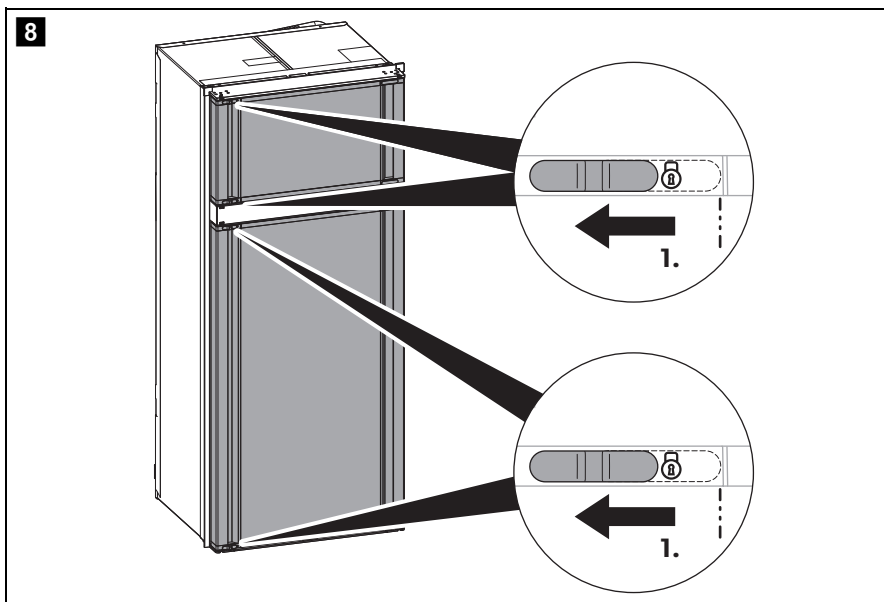

► Secure the refrigerator door as shown (fig. **8**).

6.10 Notes on storing food



CAUTION! – Health hazard!

- Please check if the temperature of the refrigerator is suitable for the food you want to store.
- Opening the door for long periods can cause significant increase of the temperature in the compartments of the refrigerator.
- Food may only be stored in its original packaging or in suitable containers.
- Store raw meat and fish in suitable containers in the refrigerator, so that raw meat and fish is not in contact with or drip onto other food.
- The freezer compartment is suitable for making ice cubes and for keeping frozen food. It is not suitable for freezing previously unfrozen food.
- If the refrigerator is exposed to a room temperature of below +10 °C for a prolonged period of time, an even temperature of the freezer compartment cannot be guaranteed. This can lead to an increase in temperature and the stored goods may defrost.

**NOTICE!**

- The maximum weight per door shelf is 6 kg. The maximum weight for the entire door is 7.5 kg.
- Store heavy objects such as bottles or cans only in the refrigerator door, in the lower storage compartment or on the bottom shelf.
- Do not keep carbonated drinks in the freezer compartment.

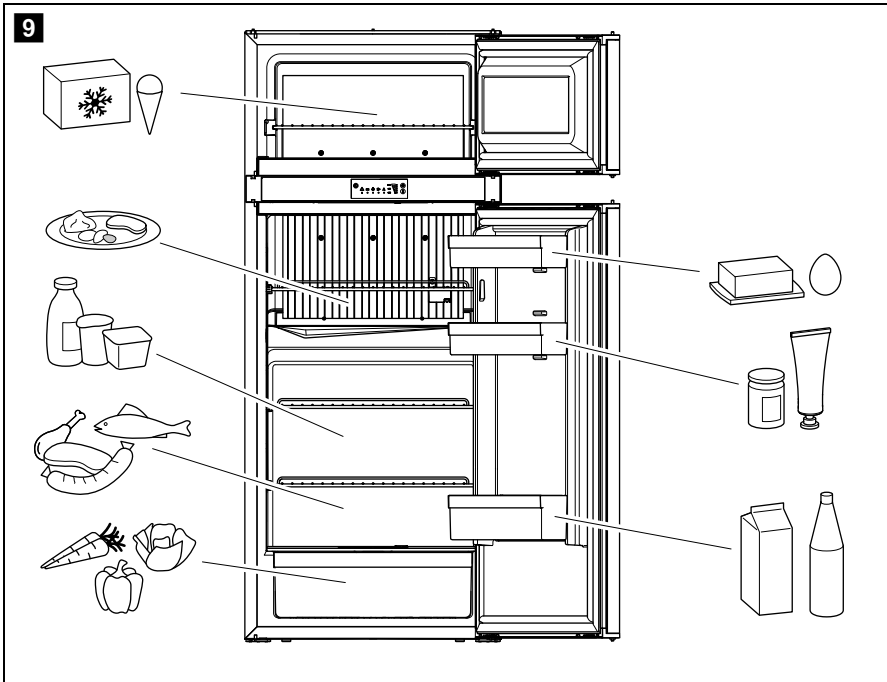

► Store food as shown (fig. **9**).



Using the VG fresh base



NOTICE!

The maximum load capacity of the VG fresh base is 5.5 kg.

The humidity in the vegetable compartment can be regulated using the slider in the VG fresh base (fig. 11, page 11) as follows:

Goods to be cooled		Optimal humidity		Slider position
Vegetables		High	△△△	► Close the slider.
Fruit		Low	△	► Open the slider.

Removing and inserting the VG-Fresh base

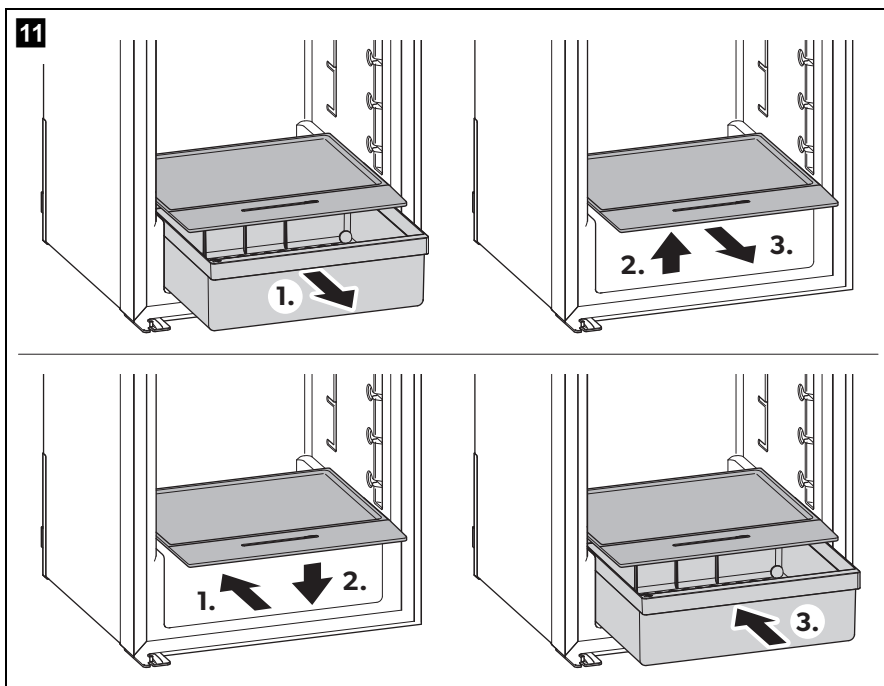

► Proceed as shown (fig. 11).

6.11 Defrosting the refrigerator



NOTICE!

Do not use mechanical tools or heating devices such as hair dryers to remove ice or loosen frozen items.

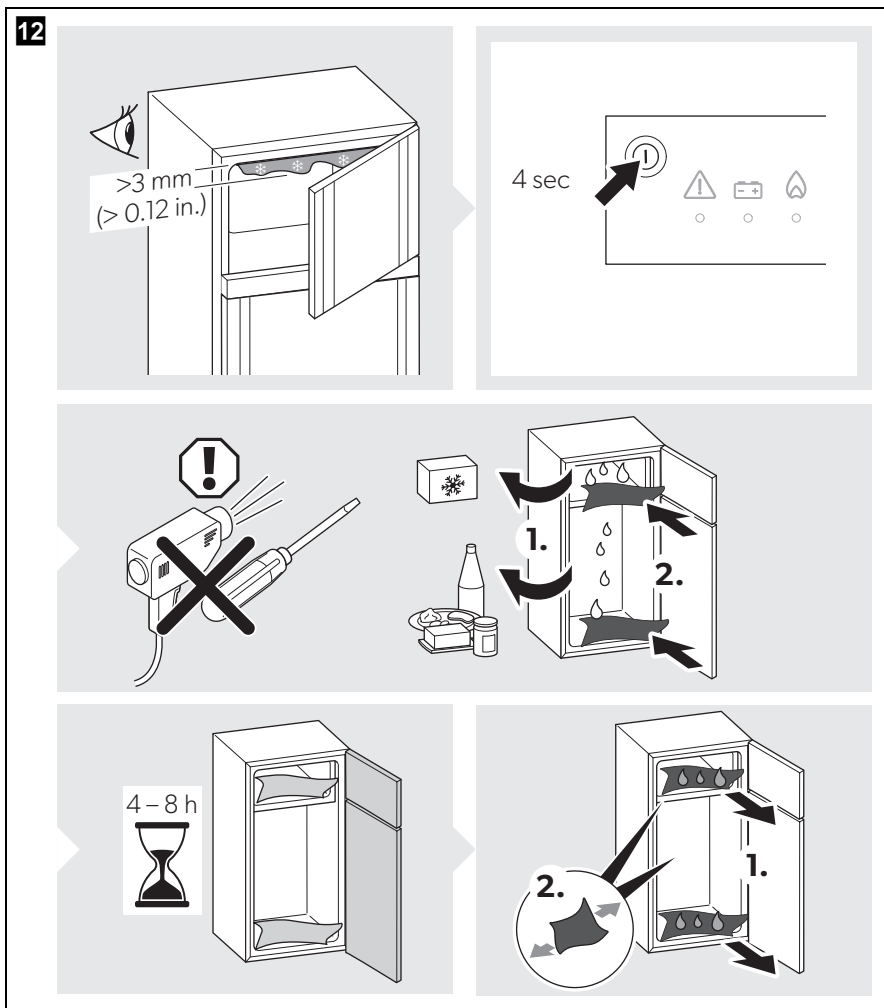

► Proceed as shown (fig. **12**).

6.12 Using the Door Airing Function



CAUTION!

The airing function must **not** be used while driving. Ensure that the refrigerator door and the freezer compartment door are closed and locked before starting to drive.



NOTICE!

Use the door airing function, if you do not intend to use the refrigerator for a prolonged period of time. This prevents mould from forming when the refrigerator is not in use or put into storage.

Proceed as follows to use the door airing function:

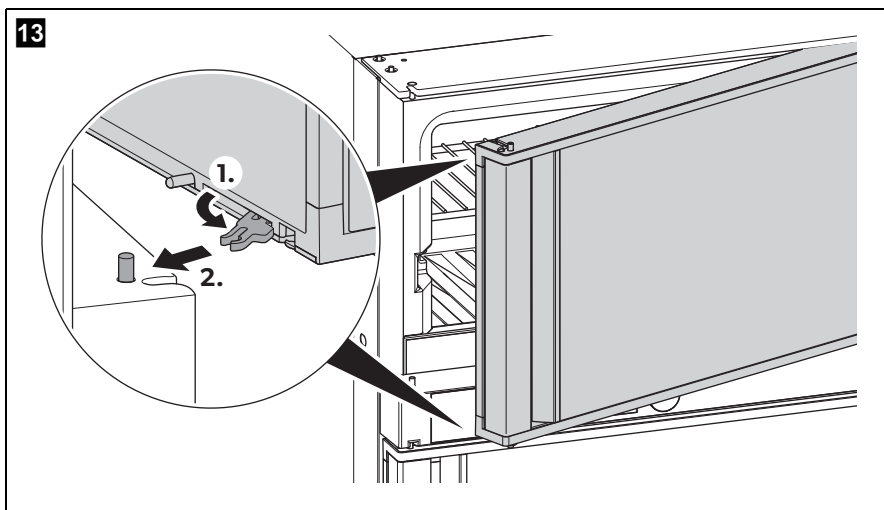

- ▶ Defrost the refrigerator (see chapter “Defrosting the refrigerator” on page 24).
- ▶ At the top and bottom of the door in the area of the locking mechanism, pull the hook all the way out (fig. **13**).
- ▶ Close the refrigerator door until the protruding pin snaps into the hook
- ✓ The protruding pin snaps into the hook.

Deactivating the door airing function

- ▶ Pull the door toward you.
- ▶ Push in the protruding hooks at the top and bottom of the door.

6.13 Optional battery backup/Stand-alone gas operation

If the caravan or motor home's 12 V DC battery power supply is unavailable or if the power supply is cut off while the device is in operation, the electronic control unit automatically switches to internal battery power (if batteries are inserted).

Also see chapter "Stand-alone gas operation" on page 18.

The compartments for the battery packs are located under the central divider between the main compartment and the freezer compartment. A total of 12 AA batteries are needed.

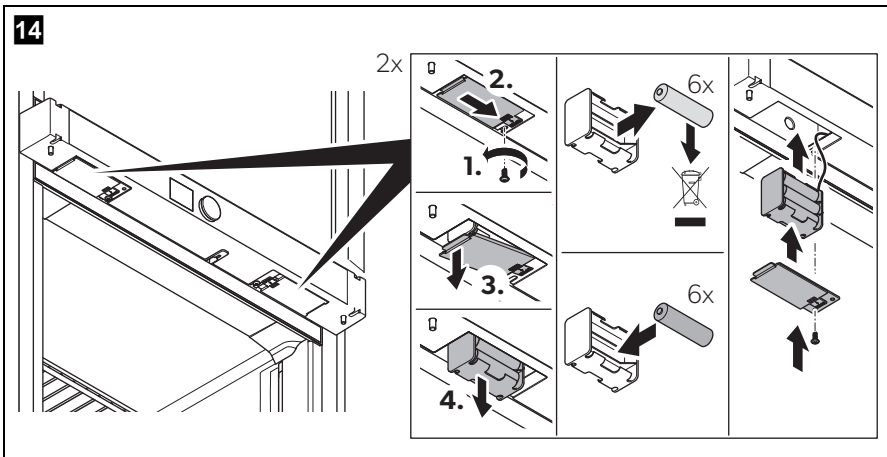

► Proceed as shown to insert the batteries (fig. 14).

7 Troubleshooting



NOTE

To safely operate 12 V consumer units in the caravan while driving, it must be ensured that the towing vehicle provides sufficient voltage. In some vehicles, the battery management system may automatically switch off the consumer units to protect the battery. Ask your vehicle manufacturer for more information.

Fault	Possible cause	Suggested remedy
With AC operation: The refrigerator does not work.	The fuse in the AC power supply is defective.	Replace the fuse.
	The vehicle is not connected to the AC power supply.	Connect the vehicle to the AC power supply.
	The AC heating element is defective.	Contact customer service for assistance.
With DC operation: The refrigerator does not work.	The fuse in the DC supply is defective.	The fuse on the relay must be replaced. Contact customer service for assistance.
	The vehicle fuse has blown.	Replace the vehicle fuse. (Please refer to the operating manual of your vehicle.)
	The vehicle battery is discharged.	Test the battery and charge it.
	The ignition is not turned on.	Switch on the ignition.
	The DC heating element is defective.	Contact customer service for assistance..
With gas operation: The refrigerator does not work.	The gas cylinder is empty.	Replace the gas cylinder.
	The gas valve is closed.	Open the valve.
	Air is in the supply line.	Switch the refrigerator off and on again. Repeat the procedure three or four times if necessary. If available, switch on the stove and repeat the process with the refrigerator if necessary.
In automatic mode: The refrigerator is being operated with gas although it is connected to the AC mains.	The mains voltage is too low.	The refrigerator changes to AC power supply automatically as soon as the mains voltage is sufficient again.

Fault	Possible cause	Suggested remedy
The refrigerator is not cooling adequately.	The ventilation around the cooling unit is not sufficient.	Check that the ventilation grill is not obstructed.
	The evaporator is iced up.	Check whether the refrigerator door closes properly. Make sure that the refrigerator seal fits correctly and is not damaged. Defrost the refrigerator.
	The temperature is set too high.	Set a lower temperature.
	The ambient temperature is too high.	Remove the ventilation grill for a while so that warm air can escape quicker.
	Too much food was placed in the refrigerator at once.	Remove one or more items of food.
	Too much warm food was placed in the refrigerator at once.	Remove the warm food and leave it to cool down before putting it in again.
	The refrigerator has not been operating long enough.	Check the temperature again after four or five hours.

7.1 Fault messages and signal tones







All faults are indicated by a warning symbol, a fault ID and a beep. The beeping lasts for 2 minutes and is repeated every 30 minutes until the error has been rectified.

If multiple faults occur, the display shows the last fault. The underlying faults are displayed after the last fault has been rectified.

In the event of a fault, the LED warning symbol () in the display lights up continuously and the LEDs flash according to the fault.

WARNING type fault messages



All faults messages of the WARNING type are reset automatically once the fault has been rectified.









Code	Fault	Solution
	Defective temperature sensor in the refrigerator compartment	Contact customer service for assistance.
	AC power not connected or AC voltage < 190 V	Connect the refrigerator to AC or select a different energy type, e.g. gas or DC.
	DC power not connected	Connect the refrigerator to DC or select a different energy type, e.g. gas or AC.
	DC overvoltage (> 16 V)	Reduce the DC supply voltage.
		
	Tank stop mode: Gas operation is blocked for 15 minutes.	Wait 15 minutes or switch to another operating mode.
Beep	The door is opened for more than 2 minutes.	Close the door.

ERROR type fault messages

All faults messages of the ERROR type must be reset manually:

- ▶ Press the  button for 2 seconds.
- ✓ A beep sounds.
- ✓ The error has been reset.

Code	Fault	Solution
	No connection between power module and display	Contact customer service for assistance.
	No cooling in gas mode	Check if the device is tilted and level it if necessary.
		Reset the error. Contact customer service if this error occurs again.

Code	Fault	Solution
	No cooling in AC mode	Check if the device is tilted and level it if necessary. Reset the error. Contact customer service if this error occurs again.
	No cooling in DC mode	Check if the device is tilted and level it if necessary. Reset the error. Contact customer service if this error occurs again.
	Gas valve check error	Gas operation is not possible. Reset the error. Contact customer service if this error occurs again.
	Internal communication error	Gas operation not possible. Reset the error. Contact customer service if this error occurs again.
	In stand-alone gas mode: The battery charge of the battery packs is too low	Insert new batteries. Reset the error.
	Gas lock after 3 ignition attempts	Ignition not possible. The gas cylinder is empty. Replace the gas cylinder. Reset the error.
	Gas lock, internal error in the power module	Reset the error. Contact customer service if this error occurs again.
	Ground contact, gas valve	Reset the error. Contact customer service if this error occurs again.
	Ground contact, ignition electrode	Reset the error. Contact customer service if this error occurs again.

8 Cleaning and maintenance



WARNING!

Always disconnect the refrigerator from the energy supply before you clean and service it.



NOTICE!

Never use sharp cleaning agents or hard or pointed tools to remove ice or to loosen objects which have frozen in place.

- Clean the refrigerator regularly and when it gets dirty using a damp cloth.
- Make sure that no water drips into the seals. This can damage the electronics.
- Wipe the refrigerator dry with a cloth after cleaning.
- Check the condensate drain regularly.
Clean the condensate drain when necessary. If it is blocked, the condensate collects on the bottom of the refrigerator.
- Make sure that the ventilation grills in the outer wall of the motorhome or caravan and the roof ventilation are free from dust and pollutants. This ensures that the heat generated during operation can be dispersed, so that the refrigerator is not damaged and the cooling capacity is not reduced.

8.1 Cleaning the gas burner



WARNING!

- Close the gas valve to the refrigerator before cleaning the gas burner.
- Allow the burner to cool down before cleaning it.
- Do not modify the gas equipment. The gas burner can be cleaned without removing the gas equipment.



NOTE

- Dirt in the gas burner becomes noticeable by poor ignition or deflagration. Look out for a popping noise if the refrigerator struggles to light when swapping to gas mode.
- The manufacturer recommends cleaning the burner at least once a year.
- The cleaning interval, depending on the degree of pollution, is reduced to half yearly or quarterly.

► Clean the gas burner as shown (fig. 15, page 32).

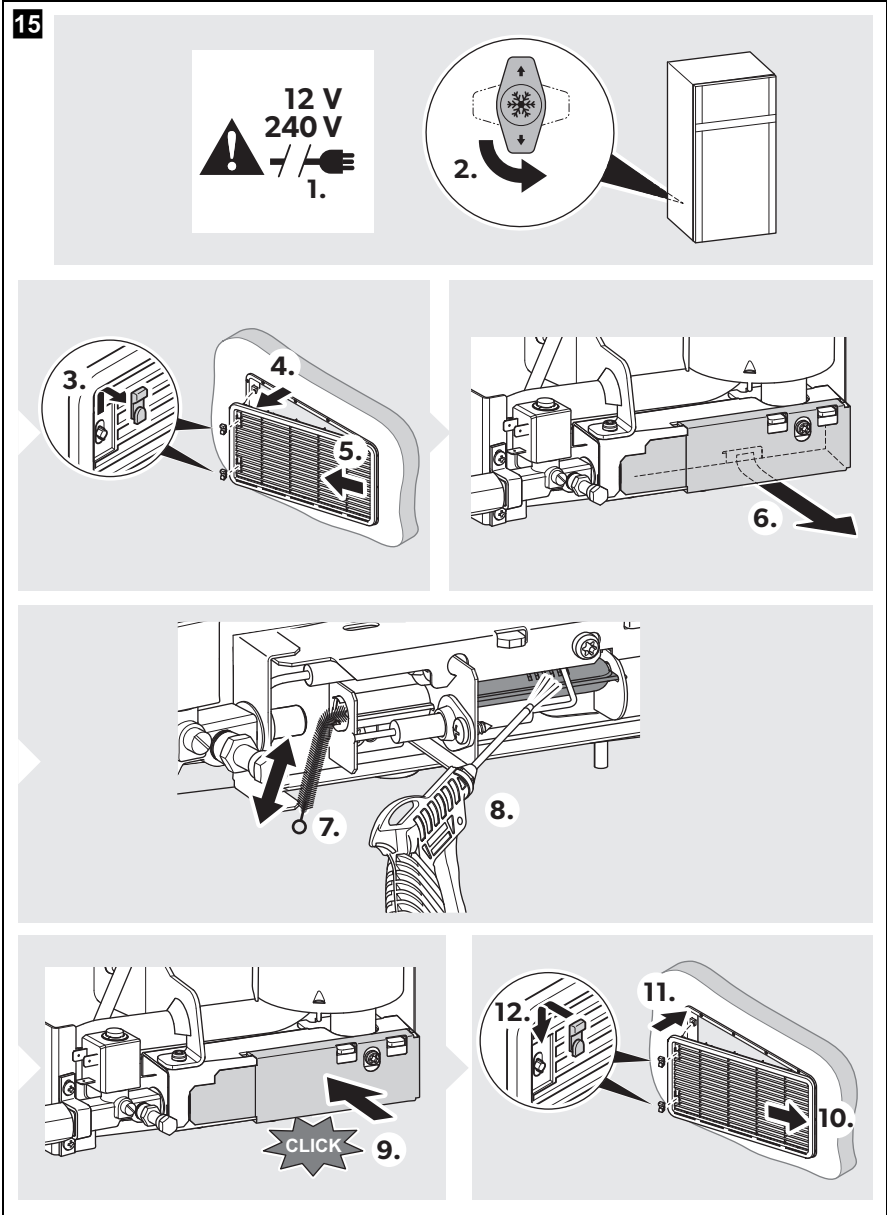

8.2 Maintenance

**WARNING!**

Work on gas and electrical installations may only be performed by qualified technicians.

- ▶ Have the gas system and connected flues inspected before initial operation and then every two years by an authorized professional to ensure they comply with the national safety requirements.
- ▶ Keep a record of any maintenance performed.

9 Warranty

If the product does not work as it should, please contact your retailer or the manufacturer's branch in your country (see dometic.com/dealer).

For repair and warranty processing, please include the following documents when you send in the device:

- A copy of the receipt with purchasing date
- A reason for the claim or description of the fault

Australia only

The warranty applicable to your product is 3 year(s).

Our goods come with guarantees that cannot be excluded under the Australian Consumer Law. You are entitled to a replacement or refund for a major failure and for compensation for any other reasonably foreseeable loss or damage. You are also entitled to have the goods repaired or replaced if the goods fail to be of acceptable quality and the failure does not amount to a major failure.

New Zealand only

This warranty policy is subject to the conditions and guarantees which are mandatory as implied by the Consumer Guarantees Act 1993(NZ).

10 Disposal



**NOTE**

This device contains flammable insulation blowing gas.
Only have the device removed and disposed of by a specialist.

**Protect the environment!**

Do not dispose of any batteries with general household waste.
Return defective or used batteries to your retailer or dispose of them at collection points.

11 Technical data

	RMD10.5XS
Total gross volume:	173 l
Fridge storage volume:	140 l
Freezer storage volume:	33 l
AS/NZS 4474.1:2007	
Connection voltage:	230 –240 V~ / 50 – 60 Hz 12 V===
Power input:	250 W (240 V~) 170 W (12 V===)
Power consumption:	5.0 kWh/24 h (240 V~)
Gas consumption:	586 g/24 h
Climate class:	T
Dimensions in mm	
Width x Height	
– without flange:	526 x 1246
– with flange:	550 x 1260
Depth	
– overall (Door slider excluded)	615
– from flange rear face:	561
Weight:	52.5 kg
Inspection/certification:	 



NOTE

The power and gas consumptions are measured at 32 °C ambient temperature with 3 °C average cooling temperature in the refrigerator compartment.

Detailed information

 dometic.com

Mobile living made easy.



dometic.com

**YOUR LOCAL
DEALER**

dometic.com/dealer

**YOUR LOCAL
SUPPORT**

dometic.com/contact

**YOUR LOCAL
SALES OFFICE**

dometic.com/sales-offices

A complete list of Dometic companies, which comprise the Dometic Group, can be found in the public filings of:
DOMETIC GROUP AB Hemvärnsgatan 15 SE-17154 Solna Sweden